

S3D^{CPM}

200U/GE-103

Shoulder CPM Device including GE-103 Portable CPM Chair

For Shoulder Flexion/Extension,
Abduction/Adduction and Rotation

Setup and Operating Manual

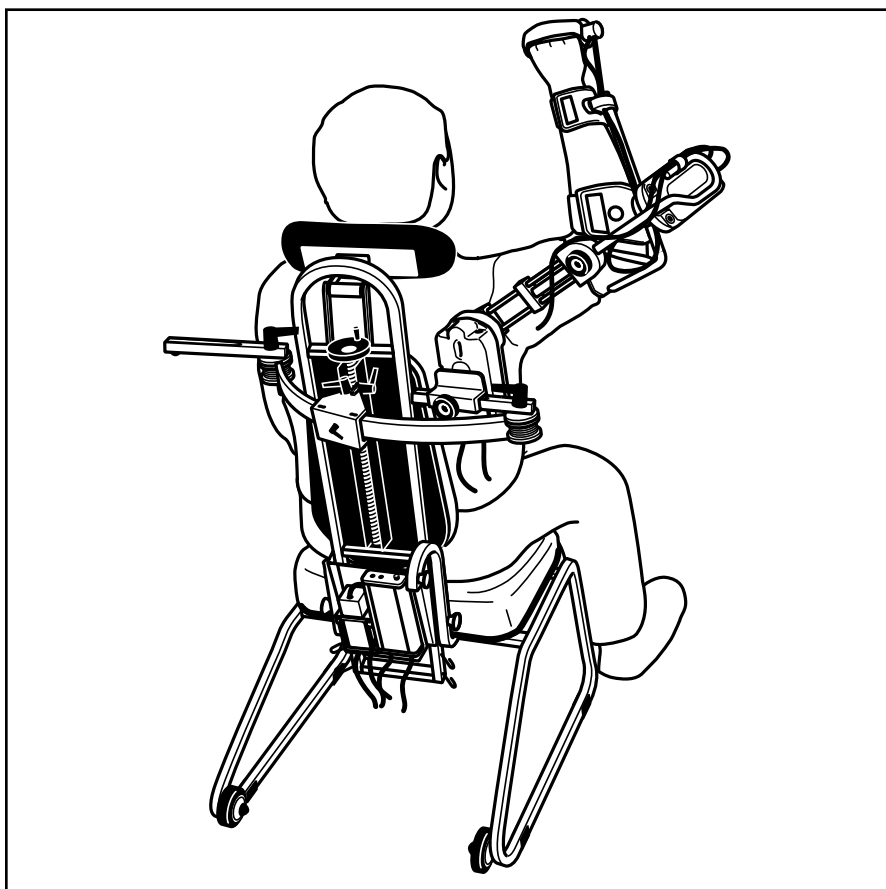

CPM Device Information	2
CPM Device Components.....	3
Attaching the Mounting Plate.....	4
Attaching the Mounting Bracket	5
Replacing Softgoods	6
Ordering Information	6
Chair Setup and Adjustment	7 - 10
Attaching the Motion Controller.....	7
Motion Controller Functions	11
Recharging the Motion Controller Battery	
Right to Left Shoulder Setup	12
Attaching the CPM Device	13
Abduction and Rotation Setup	
Forward Flexion and Rotation Setup	
Patient Alignment.....	14-15
Range of Motion	
Setting Range of Motion	16
General Overview of Programming ROM Limits.....	17 - 18
Programming Range of Motion.....	19
Abduction and Rotation ROM	20
Forward Flexion and Rotation ROM	21
Maintenance.....	22
Cautions and Warnings.....	24
Symbols and Specifications	25
Trouble Shooting	26 - 27
Warranty	28

CPM Device Information

Indications

The immediate post-operative management after the following where indicated:

Rotator cuff repair

After acromioplasty, particularly where the operation has been repeated and in cases where early physiotherapy cannot be assured

Capsulotomy and arthrolysis for post-traumatic arthritis with restriction of motion

Following total shoulder replacement

Synovectomy for rheumatoid arthritic and hemophilic arthropathy in the absence of acute inflammation, pain or bleeding

Arthrotomy and drainage for acute septic arthritis

In joint contracture after manipulation

Application

Continuous Passive Motion (CPM) is best applied immediately post-operative and continued, uninterrupted, for up to six weeks as prescribed by the Physician.

Clinical Advantages

Maintenance of a good range of motion.

Prevention of intra-articular adhesions.

Prevention of extra-articular contractures.

Reduction of post-operative pain.

Prevention of negative effects of immobilization.

Note:

Allow device to reach room temperature for a minimum of one hour prior to use.

CPM Device Components

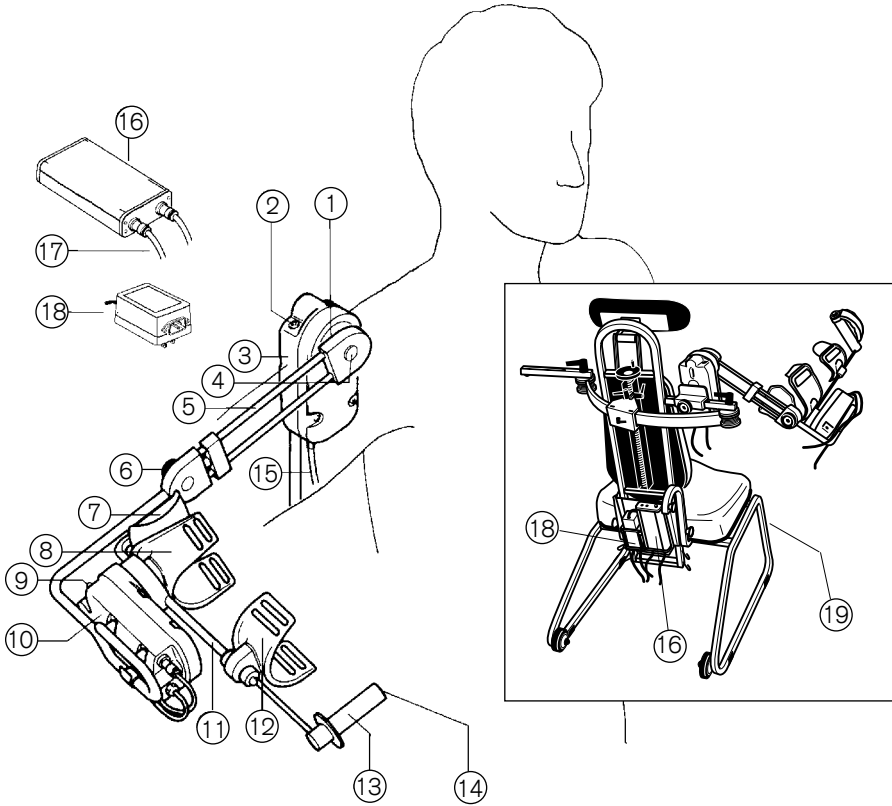

- | | |
|------------------------------------|--|
| 1. Goniometer Label | 11. Forearm Frame |
| 2. Shoulder FWD/REV Buttons | 12. Wrist Cuff |
| 3. Shoulder Actuator Drive | 13. Handle |
| 4. Lock Button – Left/Right | 14. Patient Thumb Switch |
| 5. Upperarm Frame | 15. Cable to Motion Controller |
| 6. Upperarm Locking Knob | 16. Motion Controller |
| 7. Elbow Cuff | 17. Cable to Actuator |
| 8. Forearm Cuff | 18. Power Supply |
| 9. Rotation FWD/REV Buttons | 19. Portable CPM Chair (GE-103) |
| 10. Rotation Actuator Drive | |



WARNING. Device should only be used after the operator thoroughly reads and understands this manual. See Cautions and Warnings section.

Attaching the Mounting Plate (if required)

Step One: Fit the Mounting Plate assembly onto the back of the CPM chair and attach using star washers and 6-32 nuts over the four (4) corresponding threaded studs.

Step Two: Check the ground resistance from the frame to the earth pin on the supplied power input cable using the method recommended by the IEC 601, clause 18F. The measured resistance must be less than 0.1 ohms. If the measured resistance is more than 0.1 ohms, repeat the test using the contact point on the opposite side of the frame. If the measured resistance is still more than 0.1 ohms, tighten the 6-32 nuts and retest until resistance falls to an acceptable value.

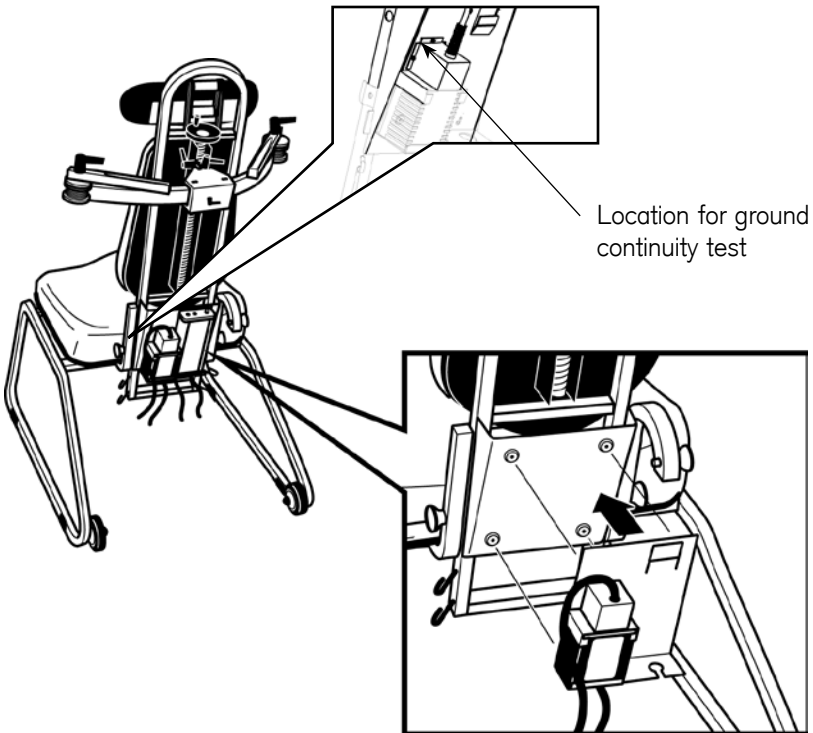

Attaching the Mounting Bracket

***The Mounting Bracket assembly must be attached to the Shoulder Actuator to convert the S3D-100U Device for use on the Portable CPM Chair.**

Installation Instructions: Locate the Mounting Bracket assembly onto the S3 housing as shown in the diagram below. Attach the Mounting Bracket by installing the four (4) attachment bolts, spacers and acorn nuts provided.

If the acorn nuts and screws become tight and the Mounting Bracket remains loose, add the flat washers provided underneath the acorn nuts.

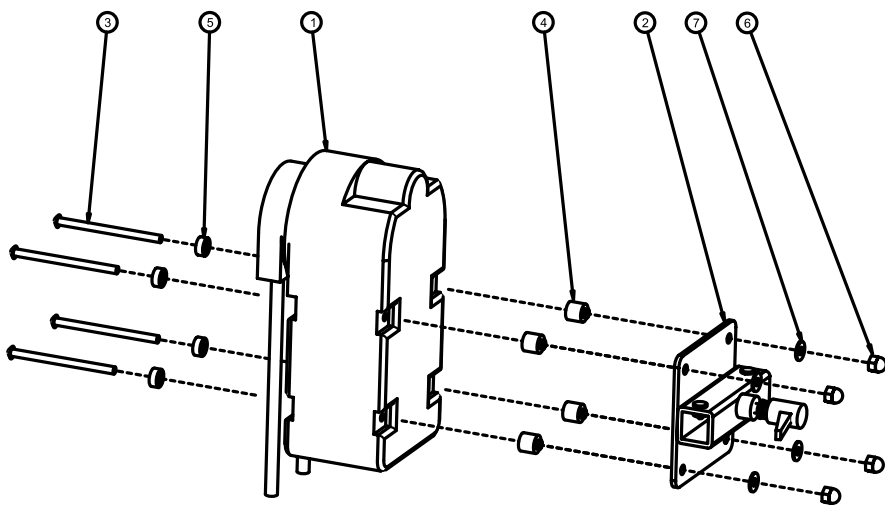

ITEM	QTY	PART #	DESCRIPTION
1	1	S3	SHOULDER CPM
2	1	S3AC033	MOUNTING BRACKET
3	4	FS1032U	10-32 SCREW
4	4	D1B003	LONG SPACER
5	4	D1B001	SHORT SPACER
6	4	FN1032E	ACORN NUT
7	8	1670019	#10 FLAT WASHER, AS REQUIRED

Replacing Softgoods

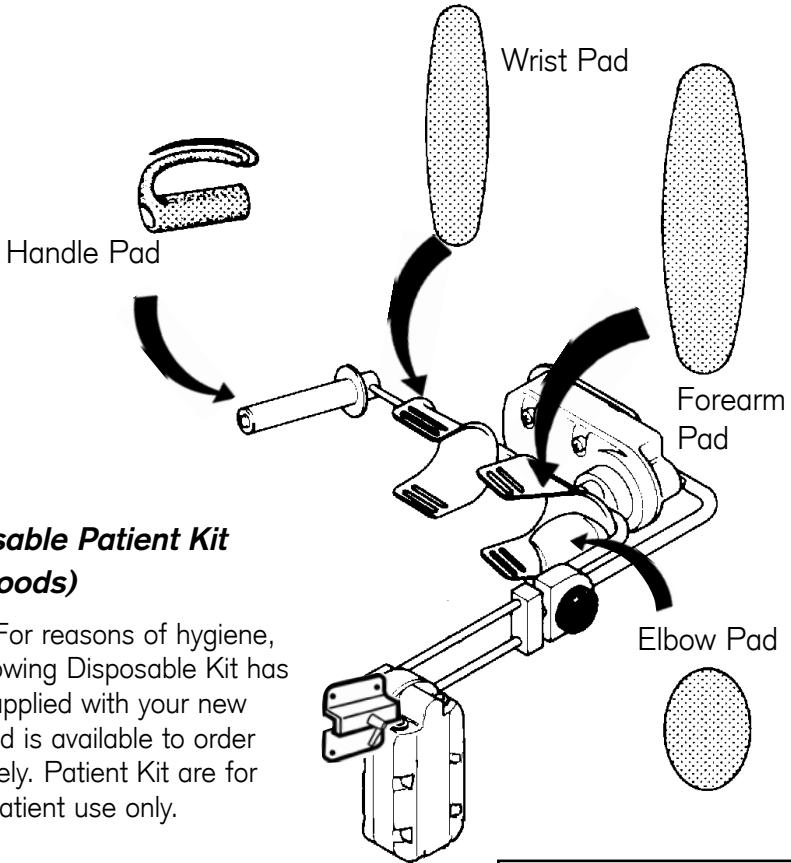

Disposable Patient Kit (Softgoods)

Note: For reasons of hygiene, the following Disposable Kit has been supplied with your new S3D and is available to order separately. Patient Kit are for single patient use only.

Ordering Information:

DESCRIPTION

DESCRIPTION	PART NO.
S3D Dual Drive Shoulder CPM – With Portable CPM Chair	S3D-200U
S3D Shoulder CPM – Requires a tripod and a steel, armless chair.	S3D-100U
Portable Tripod Mount	S3-105
Portable CPM Chair for S3D-200U	GE-103
Portable Chair Adapter Kit – Required for installation of S3S-100U or S3D-100U onto Portable CPM Chair	S3-106
Disposable Patient Kit	S3-101DS
Motion Controller	S3-104
Seat Clamp Assembly – Use with S3-105	S3-105D

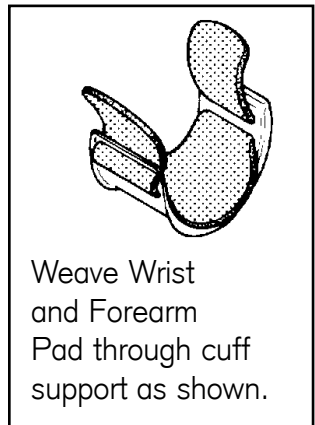

Chair Setup and Adjustment

Step One: With the chair in its upright position, pull up on the Lower Locking Buttons (A) and unfold one leg at a time. Ensure each leg is locked in position.

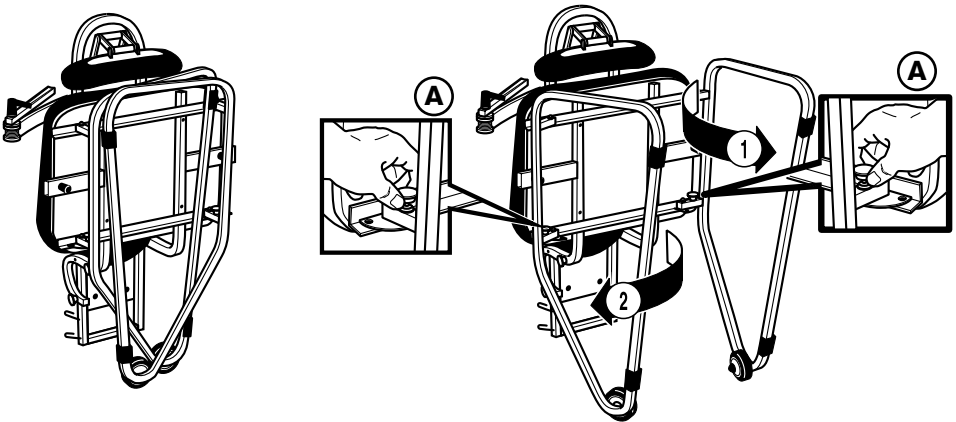

Step Two: With the chair on its legs, attach the motion controller.

Attach the Belt Clip on the Motion Controller to the tab on the Mounting Plate. Feed the power and controller cables up through the holes in the Mounting Plate and secure them into their respective sockets in the Motion Controller by tightening the locking rings.

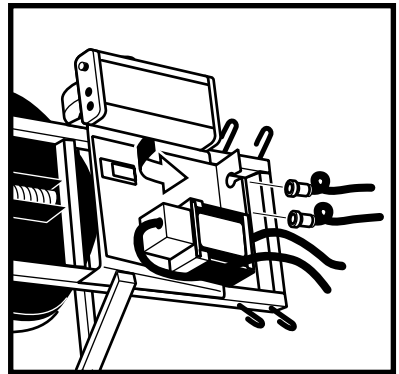

Chair Setup and Adjustment (cont'd.)

Opening the Backrest Up

Once the Motion Controller is secured, lift the Backrest slightly using your left hand and disengage the Upper Locking Button (B). Gently move the Backrest to an upright position. Ensure that both of the Lower Locking Buttons (A) are engaged and that the Backrest is secure.

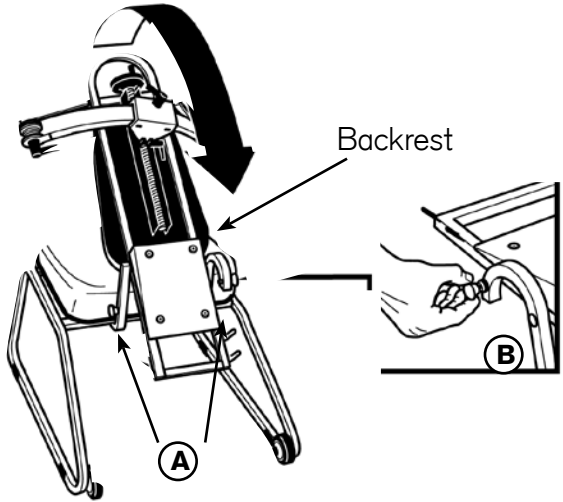

Step Three: Install the Arm Rest by releasing the Locking Button (C) located underneath the seat. Then slide the Arm Rest into the frame and ensure it locks into position.

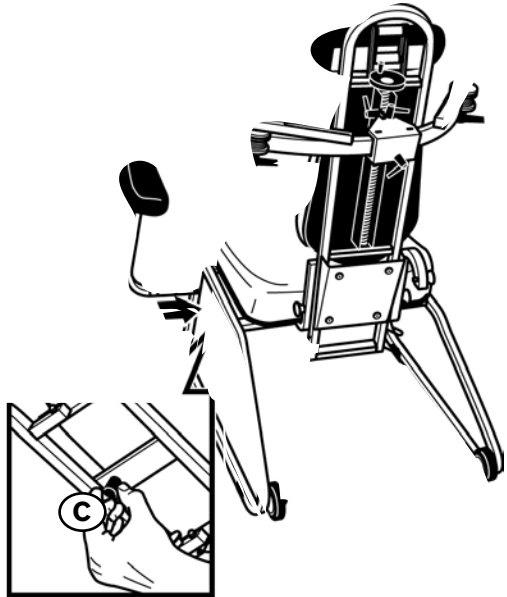

CAUTION: OBSERVE CARE IN FOLDING OR UNFOLDING THE CHAIR PARTS SO AS NOT TO PINCH HANDS OR FINGERS.

Chair Setup and Adjustment (cont'd.)

Folding the CPM Portable Chair

The following instructions are to ensure that fingers are not pinched when the Backrest on the CPM Portable Chair is folded down for storage or moving:

Folding the Backrest Down

Position yourself at the back of the Chair, facing forward. Pull out the two Lower Locking Buttons (A) on either side of the Chair and gently push the Backrest forward **slightly** to disengage the Locks. Once the two Locking Buttons are disengaged and the Backrest is unlocked, grasp the top of the Backrest with your left hand while pulling out the Upper Locking Button (B) with your right hand. Gently lower the Backrest onto the seat cushion. This procedure ensures that the Backrest does not fall rapidly onto the Seat and reduces the risk of pinched fingers.

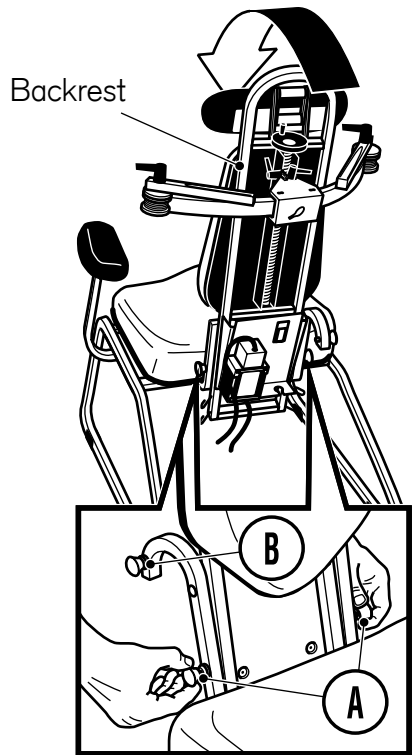

CAUTION: OBSERVE CARE IN FOLDING OR UNFOLDING THE CHAIR PARTS SO AS NOT TO PINCH HANDS OR FINGERS.

Chair Setup and Adjustment (cont'd.)

The adjustment mechanism located on the back of the chair allows for several CPM device adjustment options:

Lever A. Turret Arm horizontal adjustment.

Lever B. Left and Right pivoting of the sliding Arc Bar.

Lever C. Left and Right sliding of the Arc Bar.

Lever D, Knob E. Elevation adjustment. Loosen the two levers 'D' and turn Elevation Knob 'E'.

Using Locking Levers: Depress Lever before turning.

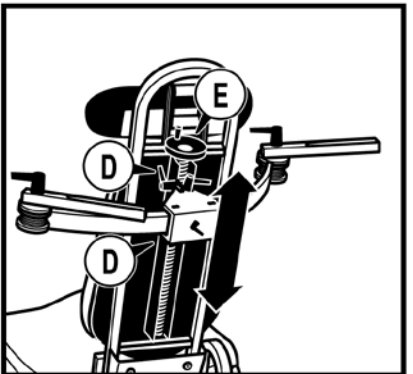
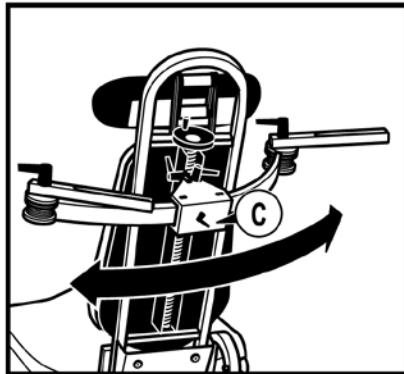
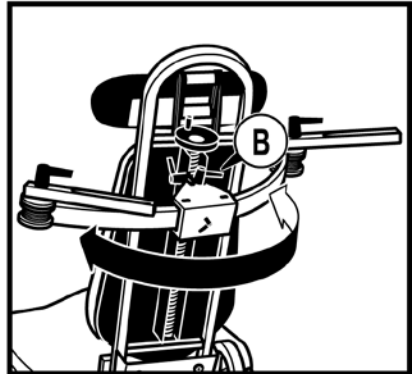
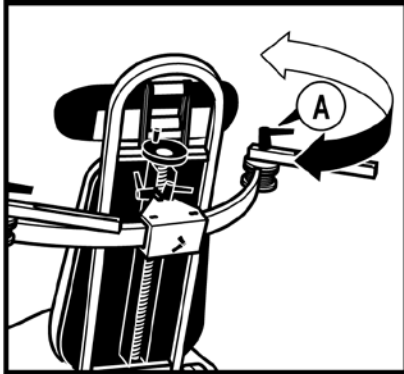

Motion Controller Functions

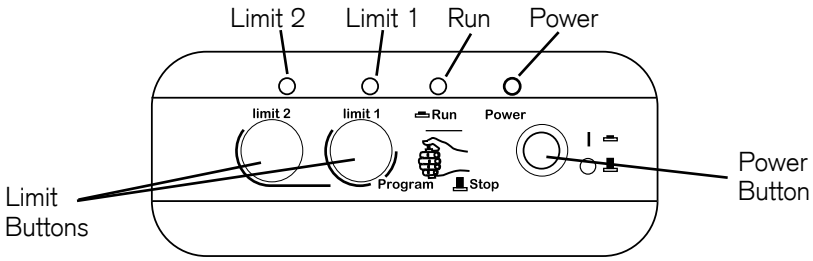

Indicator Lights (what each indicates)

Power Indicator:

ON. Indicates sufficient battery power

Flashing. Indicates low battery power

Run light:

ON. Indicates operating between set ROM Limits

Off. Indicates controller is ready to accept new ROM programming

Flashing. Indicates a malfunction; refer to Trouble Shooting Error Codes

Limit 1/2 indicators:

ON. Indicates CPM device has reached currently programmed Limit

OFF. Indicates operating within programmed Limits.

Flashing (rapidly). Indicates ready to accept new ROM programming

Flashing (slowly). Indicates the last ROM Limit has been programmed successfully.

Both ON. Indicates no ROM Limits programmed, or controller has not accepted programming.

Recharging the Motion Controller Battery

To recharge the Motion Controller, plug the Controller into the power supply. Recharging takes 6-8 hours and continues even while the CPM device is operating. Battery life is 8-10 hours.

Right to Left Shoulder Setup

Before mounting the S3 CPM device to the CPM Chair, adjust the Device for left or right shoulder set up. To adjust, depress the Lock Button and then flip the Device to the left or right side (see diagram below).

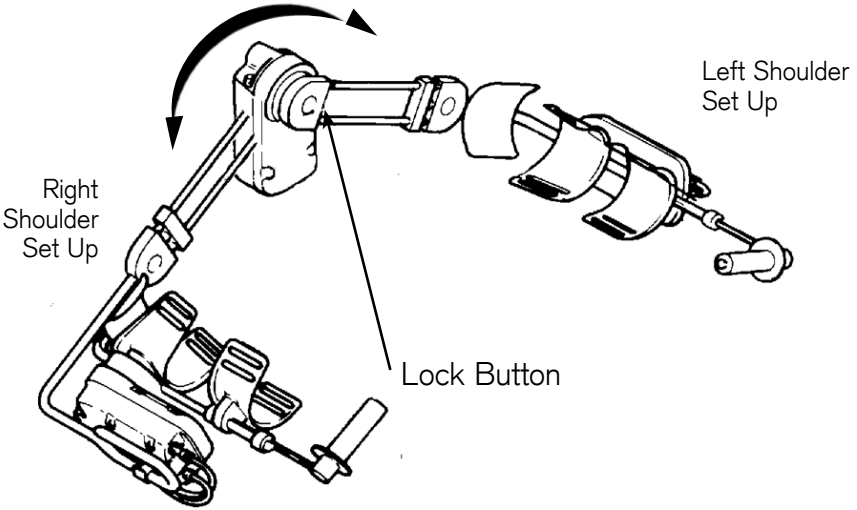

Attaching the CPM Device

For Abduction and Rotation motion

Begin with the Turret Arm pointing **inward**. Depress the Locking Pin located on the underside of the Turret Arm and, while supporting the weight of the CPM device with your hand, slide the Device onto the Turret Arm as shown in the diagram. Adjust the device according to the 'Patient Alignment' and 'Programming Range of Motion' instructions.

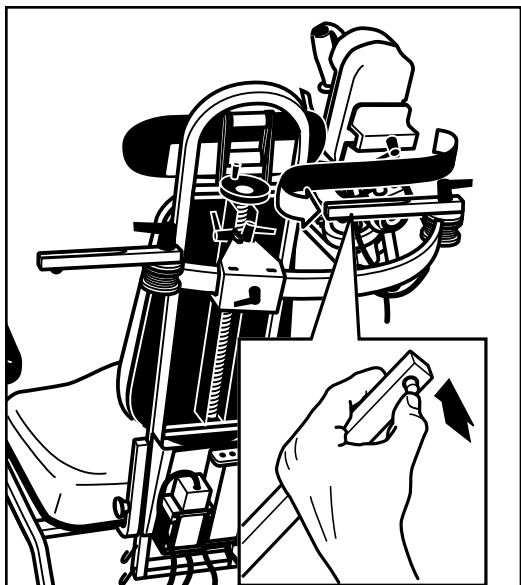

For Forward Flexion and Rotation motion

Begin with the Turret Arm pointing **outward**. Depress the Locking Pin located on the underside of the Turret Arm and, while supporting the weight of the CPM device with your hand, slide the Device onto the Turret Arm as shown in the diagram. Adjust the device according to the 'Patient Alignment' and 'Programming Range of Motion' instructions.

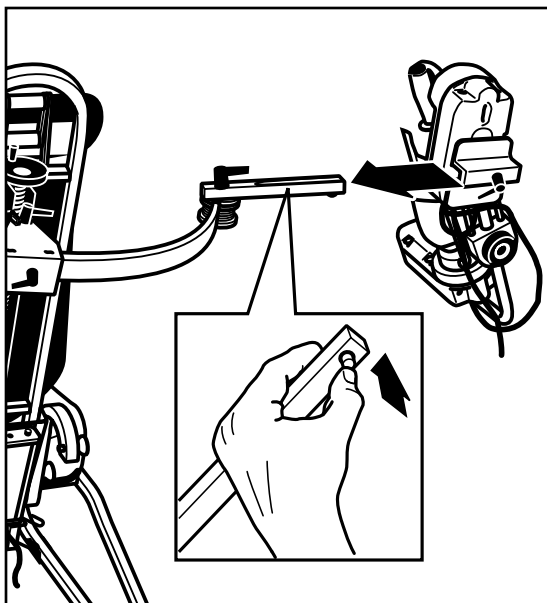

Patient Alignment

The following describes the procedure for attaching the S3 CPM Device to the patient and properly aligning the device.

Step One: Neutral Starting Position

Start patient set up by moving the S3 CPM into a neutral starting position with the FWD/REV buttons (approximately the midpoint of the physician's prescribed range of motion):

- A.** Neutral abduction or flexion position: With the FWD/REV buttons on the shoulder actuator drive, run the device into a comfortable abduction starting position.
- B.** Neutral rotation position: With the FWD/REV buttons on the rotation drive, run the Rotation drive into a comfortable rotation starting position.

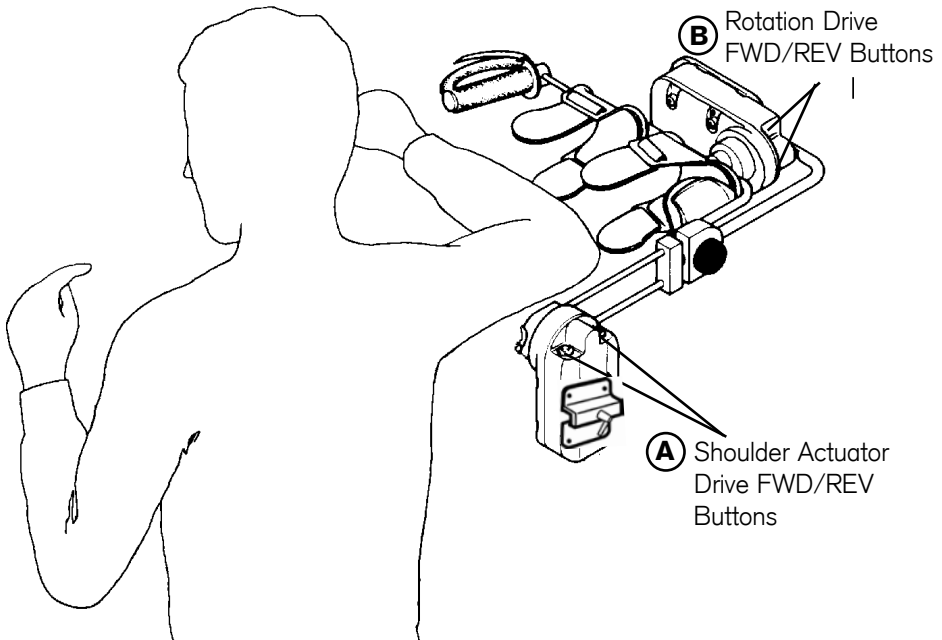

Patient Alignment (cont'd.)

Step Two: Shoulder Alignment

The main consideration in aligning the S3 to the patient's shoulder is comfort, however, as a general guide, position the S3 so that the Lock Button aligns with the centre of the patient's shoulder (see diagram). Accomplish this by adjusting the Elevation and Arc Bar Pivot and Sliding mechanisms on the back of the chair. See page 10.

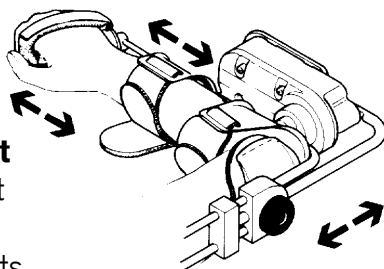
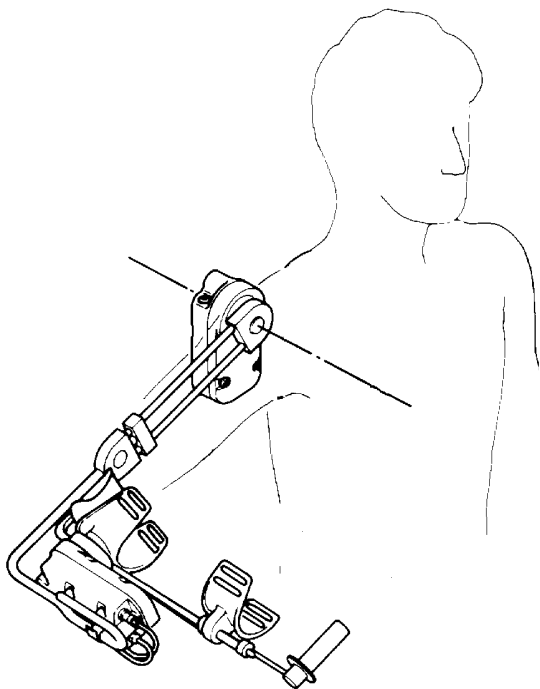

Step Three: Arm Length Adjustment

Adjust the length of the arm supports to fit the device to the arm. Ensure the hand is secure in the palm grip. Tighten Patient Kits when finished.

Range of Motion

Setting the Range of Motion

The S3-D can provide rotation with Abduction/Adduction, or Flexion/Extension, or any combination of the motions.

Figure A

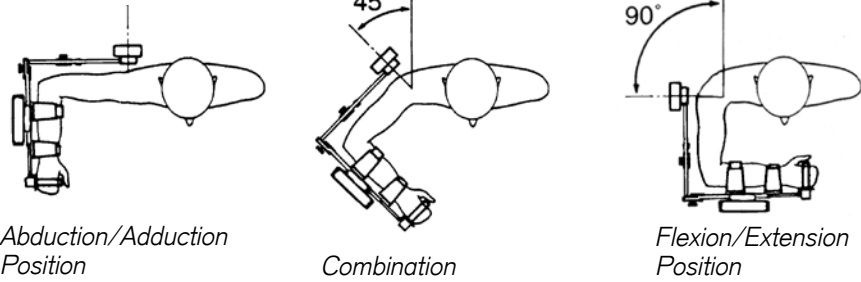

To change from Abduction to Flexion depress the locking pin and slide the CPM Device off the turret arm. Reinstall the CPM Device according to the instructions on page 13.

General Overview of Programming ROM Limits

- Setting the range of motion for the S3D requires programming only two points, the beginning point of the range of motion, Limit 1, and the end point of the range of motion, Limit 2. The S3D's user friendly Motion Controller will memorize the motion path of both actuators between the two set limits.
- Setting of Abduction/Adduction or Flexion/Extension Motion is controlled by the FWD/REV Buttons on the Shoulder Actuator.
- Setting of Internal/External Rotation and the flexion/extension Motion is controlled by the FWD/REV Buttons on the Rotation Actuator.
- To set the range of motion as prescribed by the patient's physician, proceed by following the directions on the S3D Motion Controller Label or see Programming on pages 19 - 21.
- To begin treatment, start the Device by having the patient depress the On/Off Button on the Patient Thumb Switch located on the Handle.
- Take the patient through the full path of motion established by the range of motion limits, monitoring patient comfort and tolerance. Expand or reduce the range of motion as required for patient comfort using the following procedure:

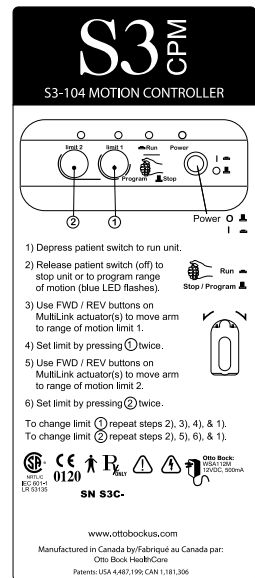
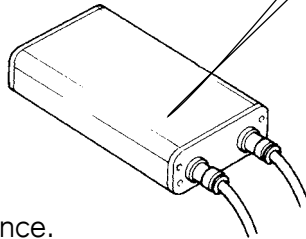

Range of Motion

Changing Range of Motion

- Run the device until a Blue LED turns on. Stop the device with the Patient Thumb Switch. Identify which LED is ON to indicate that Limit 1 (one) or Limit 2 (two) has been reached. Use the FWD/REV Buttons to change the Range of Motion. Press the same Limit Switch indicated by the previously lit Blue LED to store the new Limit. Press the Patient Thumb Switch to start the device.
- When setting a new Limit, do not cross the Set Position of the other Limit or come within 5 (five) degrees of that limit. If this happens, the controller will not accept the program changes and will need to be re-programmed.
- To reset the controller, press both Limit Switches twice and start the programming procedure again beginning with Limit 1.
- The controller automatically erases the programmed ROM three minutes after the power switch has been turned off. This is done to prepare for a new patient and new program.
- To retain the programmed ROM in memory for treating the same patient at a later time, leave the power switch on continuously.

Programming Range of Motion

Before Starting: Ensure the device is turned on at the Power On/Off button on the Motion Controller, and the Patient On/Off Thumb Switch is turned off.

Step One: With the FWD/REV buttons run the Shoulder Actuator Drive and then the Rotation Drive sequentially, until the first desired ROM limit is reached. Then press the Limit 1 button twice. The light should go from flashing quickly to flashing slowly. For more information see the following 'Abduction and Rotation ROM' instructions on page 20 or forward Flexion and Rotation ROM on page 21.

Step Two: With the FWD/REV buttons run the Rotation Drive and then the Shoulder Actuator Drive sequentially in the reverse direction, until the second desired ROM limit is reached. Then press the Limit 2 button twice.

Step Three: To begin treatment start the device with the Patient On/Off Thumb Switch. The Motion Controller will start the Actuators running in reverse order to the sequence programmed.

Diagram
Setting Range of Motion

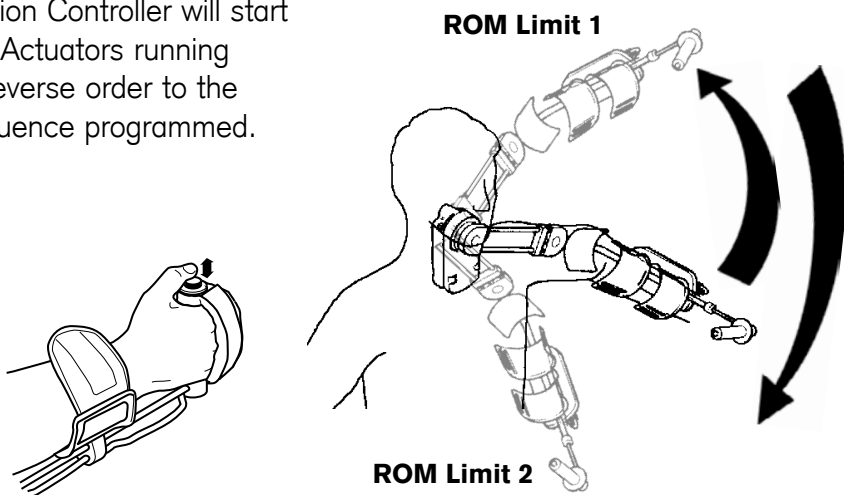

Abduction and Rotation ROM

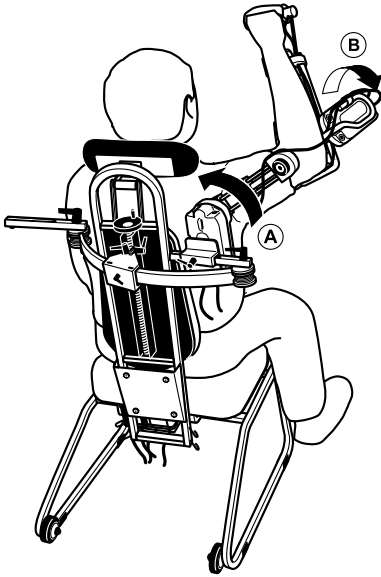

Step One: Setting ROM Limit 1

With the FWD/REV buttons run the Shoulder Actuator Drive (A) and then the Rotation Drive (B) sequentially, until the desired range of motion limit is reached. Then press the Limit 1 button twice.

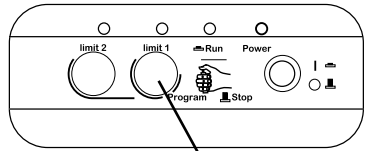

Depress Limit 1 twice

Step Two: Setting ROM Limit 2

With the FWD/REV buttons run the Rotation Drive (C) and then the Shoulder Actuator Drive (D) sequentially in the reverse direction, until the desired range of motion limit is reached. Then press the Limit 2 button twice.

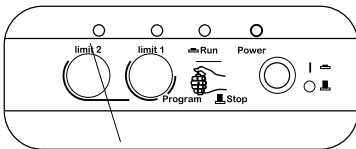
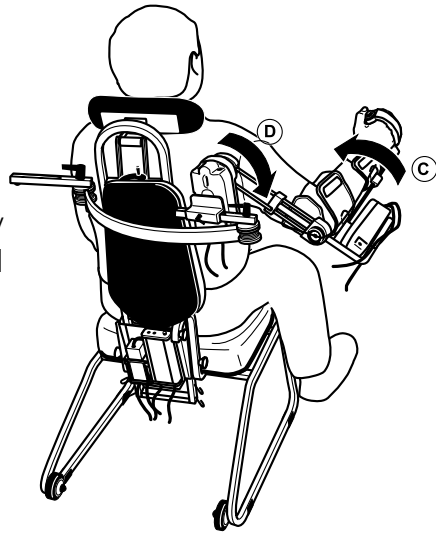

Depress Limit 2 twice

Step Three: To begin treatment start the device with the Patient On/Off Thumb Switch.

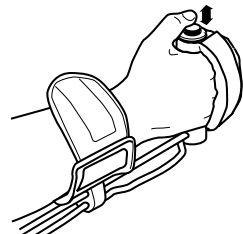

Forward Flexion and Rotation ROM

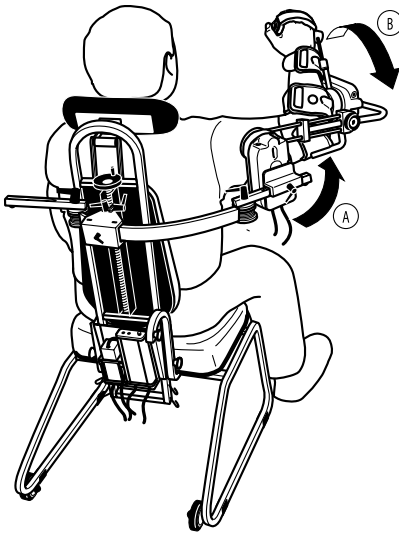

Step One: Setting ROM Limit 1

With the FWD/REV buttons run the Shoulder Actuator Drive (A) and then the Rotation Drive (B) sequentially, until the first range of motion limit is reached. Then press the Limit 1 button twice.

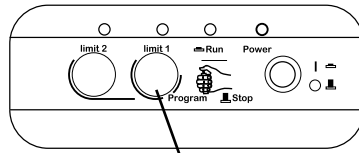

Depress Limit 1 twice

Step Two: Setting ROM Limit 2

With the FWD/REV buttons run the Rotation Drive (C) and then the Shoulder Actuator Drive (D) sequentially in the reverse direction, until the second range of motion limit is reached. Then press the Limit 2 button twice.

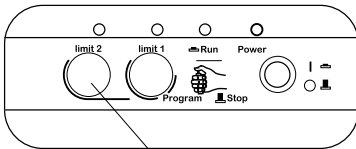
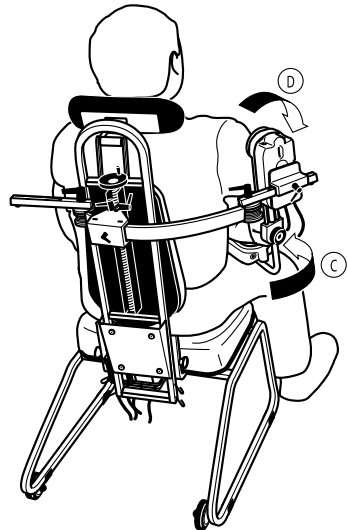

Depress Limit 2 twice

Step Three: To begin treatment start the device with the Patient On/Off Thumb Switch.

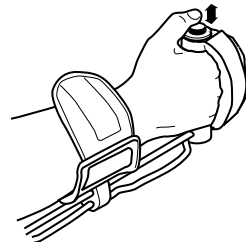

Maintenance

- The device is equipped with a rechargeable battery. Connecting the device's power supply to the power input recharges the battery.
- The battery requires 6-8 hours to fully recharge. Battery charging status is indicated by the light emitting diode (LED) just below the controller power switch. A flashing LED indicates that the battery needs to be recharged.
- The device can be operated independently by the battery for approximately 8-10 hours depending on the battery charge and the mass of the patient.

Maintenance by Patients

- Patients are responsible for using the device according to the Setup and Operating Manual. Do not wash Patient Kits.

Maintenance Between Patients

- Patient Kits for the device are for single patient use only and cannot be washed for reuse.
- Check the entire device for any visible evidence of damage, such as bent components, cracked or broken covers, frayed or damaged wires, etc. If any signs of damage are found, the device must be repaired before use.
- Ensure that all knobs and/or levers are usable and in place.
- Ensure that all moving components move freely as required.
- Check all displays and electronic controls for proper operation.
- Check all mechanical pivot and linkage points for smooth operation and secure mechanical connection. Make sure all screws, nuts, bolts, rivets, pivot pins, and other fasteners are secure.
- Gently wipe clean all exposed surfaces with a soft cloth dampened with a mild soap solution or alcohol. Do not use abrasive cleansers. To disinfect, wipe all exposed surfaces with a 10% solution of bleach and water, or other suitable disinfectants.
- Ensure that all labels are present.
- Replace the Patient Kit.
- Verify that the device operates to its set limits over several complete cycles.

Maintenance Every Six Months

- Repeat steps under "Maintenance Between Patients".

- Every 2000 hours or 6 months, run machine unloaded and listen for unusual sounds. Squeaking usually results from inadequate lubrication.
- Perform a complete check of electronic and mechanical safety systems including the Reverse-On-Load function.

Maintenance Every Twelve Months

- Verify electrical ground continuity where applicable from the device frame to ground pin of the power supply, if so equipped, using a Safety Analyzer or appropriate device.
- Repeat "Maintenance Between Patients" procedures.
- Repeat "Maintenance Every Six Months" procedures.

Maintenance Every Eighteen Months

- A full inspection of the device by a properly trained Service technician is recommended every 18 months.
- Repeat steps "Maintenance Every Twelve Months".
- Fully inspect all internal and external mechanical and drive components, and repair or replace as necessary.
- Fully inspect all internal and external electrical components (including wire connectors and solder joints), and repair or replace as necessary.
- Complete a final check of the device in accordance with Otto Bock Final Inspection criteria. (These are available through your Otto Bock representative, Otto Bock Customer Service, or your local distributor.)

Cleaning Instructions for CPM Device

Immediately following each patient use, the CPM patient kit should be removed and discarded and the unit cleaned. ORTHOREHAB devices are constructed with components made from aluminum (silver), stainless steel (silver), polycarbonate plastic (blue), modified polyphenylene oxide plastic (light blue, trade name NORYL), acetal plastic (white), polypropylene plastic (translucent white), polyethylene plastic (translucent white), nylon web straps (black). These materials offer excellent resistance to common cleaning materials such as soaps and mild cleaning agents when used as recommended.

Cautions and Warnings

1. Use a cloth and a mild soap solution to remove dirt and deposits.
 2. Wipe soap deposits from the equipment using a clean damp cloth.
 3. For stubborn areas, use a household spray cleaner applied to a soft cloth. After cleaning, wipe off residue immediately with a water-dampened cloth.
 4. Do not pour cleaning solution directly onto the machine. This may allow fluids to enter the machine and cause electrical problems, or wash lubricants away from running components reducing the life span of the device.
 5. NEVER IMMERSER THE DEVICE IN FLUIDS. The clean CPM device must be equipped with a new patient kit prior to use by the next patient.
- Do not expose the device to water or extreme temperatures. See recommended Operating and Storage Conditions.
 - Do not use the device near exposed flames, while smoking or near excessive heat.
 - Disconnect the electrical supply before servicing or cleaning. Failure to do so could result in electrical shock or personal injury.
 - Turn the power off before unplugging.
 - Unplug the power supply by grasping the plug not the cord.
 - Unless using the device or recharging the battery, turn the device off and unplug from the power supply.
 - Do not use the device, power supply or controller if it appears damaged or if there are exposed wires.
 - Store the device in its carrying case (if applicable) when not in use.
 - Do not pour cleaning solution directly onto the device. This may allow fluids to enter the device and cause electrical problems, or wash lubricants away from running components, reducing the life span of the device.
 - Select a location for the device and device components (controller, straps, cables and power supply) to prevent a tripping hazard during use or storage.

Sterilization

- This device does not require sterilization for use.
- Exposing the device to sterilization conditions will damage the device and may result in a potential hazard.
- Use the device only in accordance with the Physician prescription and Setup and Operating Manual. Failure to do so may result in damage to the device and/or personal injury.
- Patient Kits are for single patient use only.
- The device should not be used in the presence of flammable anesthetics.
- Use only manufacturer's supplied replacement components.
- Do not use the device if there are mental or physical conditions that preclude patient compliance.
- To prevent potential physical injury, such as strangulation and choking hazards, keep the device away from children or individuals with mental or physical conditions that preclude the safe use of the device.
- Position the device in a comfortable and secure position. Ensure that the device is stable through its full range of motion.
- Keep hair, loose clothing, fingers and all parts of body away from moving components of the device.

Contraindications

Do not use the device if any of the following are present:

- Untreated or uncontrolled infection.
- Unstable fractures.
- Hemorrhage.

Note: Upon using the device, if signs of infection such as hyperthermia, fever, redness, irritation, warmth, swelling, bleeding, and/or increased persistent pain are present, discontinue operation of the device and contact the patient's physician. Do not proceed with treatment until the physician has approved continued use of the device.

Symbols and Specifications

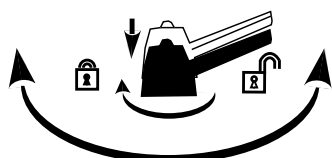
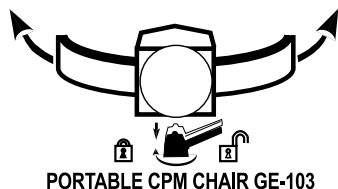
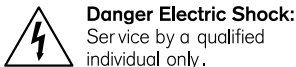

WARNING: DO NOT TRANSPORT WITH THE BACK REST IN UPRIGHT POSITION

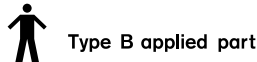
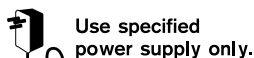
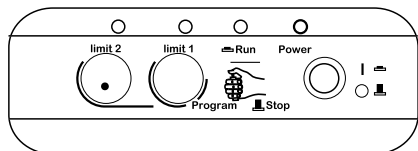

Weight:

CPM Device	6.4 kg (14 lbs.)	Chair	20 kg (44 lbs.)
------------	------------------	-------	-----------------

Range of Motion:

External Rotation	0° to 85°	Internal Rotation	0° to 85°
Forward Flexion	0° to 135°	Extension	0° to 135°
Abduction/Adduction	0° to 135°		

Rate of Motion:

110° per min.

Power Supply:

Input: 100-250 VAC, 50-60 Hz, 40VA
Output: 12VDC, 1.25A

Battery Life:

8-10 hours

Mode of Operation:

Continuous

Electric Shock Classification:

Class 1

Electric Shock Protection:

Type B

Environmental Conditions:

Temperature -10°C to 35°C (14°F to 95°F),
Humidity 90% Maximum
The device must remain in the operational environment a minimum of one hour prior to use.

ATM pressure:

750 hPa to 1040 hPa

Note: Equipment not suitable for use in the presence of flammable anesthetic mixture with air or Nitrous Oxide.

Trouble Shooting

Problem	Probable Cause	Solution
Power light does not light up	Fully discharged battery/ blown fuse	Plug in power supply, recheck after charging.
Flashing run light	Malfunction	Switch off power, check all connectors. Reprogram & restart. If problem persists, check error codes.
Constant run light with device not running	Setup error	Switch off power. Reprogram & restart. If problem persists refer to service.
Device will not move with the setup button	Hitting safety stop	Depress opposite FWD/REV button.

Error Codes

Error codes are displayed using the indicators in the Motion Controller Front Panel. To display error codes, depress either Limit 1 or Limit 2 with the “Run” indicator flashing

a) Limit 1 Depressed

Indicator “ON”	Problem	Cause/Solution
Power	Reversed on load 3 times within the last 10 seconds	Check for obstruction, clear, reprogram and restart. If problem persists, refer to service.
Run	Out of range, reversed on load while driving towards range	Check for obstruction, clear, reprogram and restart. If problem persists, refer to service.
Limit 1	Out of range, driving in the wrong direction	Hardware error. Refer to service.
Limit 2	Not used	
None		Depressed Limit 2.

Trouble Shooting (cont'd.)

b) Limit 2 Depressed

Indicator “ON”	Problem	Cause/Solution
Power	Shoulder Actuator angle measurement out of range	Check all connectors reprogram and restart. If problem persists, refer to service.
Run	Rotation angle measurement out of range	Check all connectors, reprogram and restart. If problem persists, refer to service.
Limit 1	Cable fault, controller to patient switch	Check all connectors, reprogram and restart. If problem persists, refer to service.
Limit 2	System over voltage Faulty battery/ charger	Check all connectors, reprogram and restart. If problem persists refer to service.
None		Depressed Limit 1.

New Product Limited Warranty

Otto Bock HealthCare Canada Ltd. warrants the product to be free from defects in material and workmanship for a period of (2) two years for all major components (motor, power transmission parts and circuit boards) and for a period of 90 days for all housing parts, knobs, hardware and sub-assemblies (excluding disposables). The warranty takes effect from the date of the original purchase from Otto Bock, or its Authorized Distributor, or the original activation date into the Otto Bock rental pool and provided the product is new and unused.

No warranty shall apply if the product has been lost, or damaged by accident, abuse, misuse, or misapplication, or as a result of service or modification by other than a person authorized by the Company. This warranty shall only apply to the original buyer of the product and is non transferable. The Company's liability under this warranty, and the original buyer's exclusive remedy, is limited to the cost of materials and labor to repair the defective product, or to its replacement, and in no event shall exceed the purchase price.

To obtain warranty service the product must be returned freight prepaid to the Company or the selling distributor, with a clear indication as to the defect. Upon receipt of a product returned under warranty, the Company will inspect the product and will notify the buyer of the extent of repair or replacement which the Company will perform under warranty. If the product is received incomplete, missing parts will automatically be replaced at the buyer's expense. The Company also reserves the right, at its own cost, to upgrade or replace parts or sub-assemblies to the latest production standards. The Company will normally perform the repair and return the product, or provide a replacement, within (30) days from the day of receipt, freight collect.

THE COMPANY IS NOT RESPONSIBLE FOR INCIDENTAL OR CONSEQUENTIAL DAMAGES RESULTING FROM THE BREACH OF ANY EXPRESSED OR IMPLIED WARRANTY, INCLUDING DAMAGE FOR PERSONAL INJURY. THE WARRANTY CONTAINED HEREIN IS IN LIEU OF ALL WARRANTIES, EXPRESSED OR IMPLIED, INCLUDING IMPLIED WARRANTIES OF MERCHANTABILITY AND FITNESS FOR A PARTICULAR PURPOSE. NO STATEMENT OF ANY REPRESENTATIVE SHALL EXTEND THE COMPANY'S LIABILITY AS HEREIN ESTABLISHED OR LIMITED.

Returning the Device for Service

Should the device require warranty repair, buyer must contact either the Customer Service department (outside the USA contact International Customer Service), or the authorized distributor from which the device was purchased for return instructions.

If any warranted product is found by the Company to have a defect covered by this warranty, the Company shall, at its option, either repair the defective item or install a replacement.

If the device needs to be returned for any repair, pack the components in the original shipping container and contact:

In the USA:

OrthoRehab
Attn: Technical Service
800-225-1814
Website: www.orthorehab.com

International Customer Service:

OrthoRehab
Attn: Customer Service
901 Dillingham Road
Pickering, Ontario
L1W 2Y5 Canada
Tel: 905-420-3303 Fax: 905-420-3970

Notes

CUSTOMER CONTACTS:

In the USA:

Otto Bock HealthCare

Website: www.ottobockus.com

1-800-225-1814

International:

Otto Bock HealthCare

901 Dillingham Road, Pickering,

Ontario, L1W 2Y5 Canada

1-905-420-3303 Fax 1-905-420-3970



ORTHOREHAB

901 Dillingham Road, Pickering, Ontario L1W 2Y5 Canada

Intl. Tel: 1-905-420-3303 Fax: 1-905-420-3970



RSQR Ltd. Ludgate House, 107-111

Fleet Street, London EC4A 2AB

info@rsqa.co.uk www.rsqa.co.uk



ORTHOREHAB is registered to ISO13485 for Quality Assurance